

Kahlenberg BETTER BY DESIGN

KAHLENBERG ZERO SERIES AIRHORNS ARE THE PERFECT CHOICE FOR ANY VESSEL, WHETHER DESIGNED FOR PLEASURE OR COMMERCIAL SERVICE. THEY MEET OR EXCEED THE U.S. COAST GUARD AND INTERNATIONAL MARITIME ORGANIZATION SAFETY REGULATIONS FOR VESSELS LESS THAN 20 METERS IN LENGTH. SINCE KAHLENBERG AIRHORNS ARE VERY CONSERVATIVE WITH REGARD TO AIR CONSUMPTION, THEY CAN BE OPERATED WITH AN EXTREMELY SMALL COMPRESSOR-TANK KIT AS ILLUSTRATED HEREIN.

THE DISTINCTIVE SOUND OF THESE AIRHORNS IS SCIENTIFICALLY DEVELOPED FOR VOLUME, AUDIBILITY, AND RICHNESS OF TONE, BASED ON MUSICAL INSTRUMENT DESIGN. KAHLENBERG AIRHORNS REQUIRE LITTLE MAINTENANCE. THEY DO NOT REQUIRE TUNING ADJUSTMENTS, AND INCORPORATE NO MOVING PARTS OTHER THAN THE SOUND PRODUCING DIAPHRAGM. ALL HORN CASTINGS ARE OF ACCURATELY MACHINED BRONZE, WHILE HORN PROJECTORS ARE SPUN BRASS. THREE FINISHES ARE NOW AVAILABLE INCLUDING BUFFED BRASS, CHROME PLATE, OR WHITE POWDERCOAT.



**MODEL S-0A
(BRASS FINISH)**

TECHNICAL DATA, S-0A

FREQUENCY: 322 HZ
 SOUND PRESS. LEVEL: 122.9 DB
 (1/3 OCTAVE @ 1M)
 AIR CONSUMPTION: 7.5 C.F.M. @ 100 P.S.I.
 AIR PRESSURE REQUIRED: 50 TO 200 P.S.I.
 MATERIAL: SPUN BRASS AND
 CAST BRONZE
 NET WEIGHT: 4.75 LBS.
 SHIPPING WEIGHT: 9 LBS.

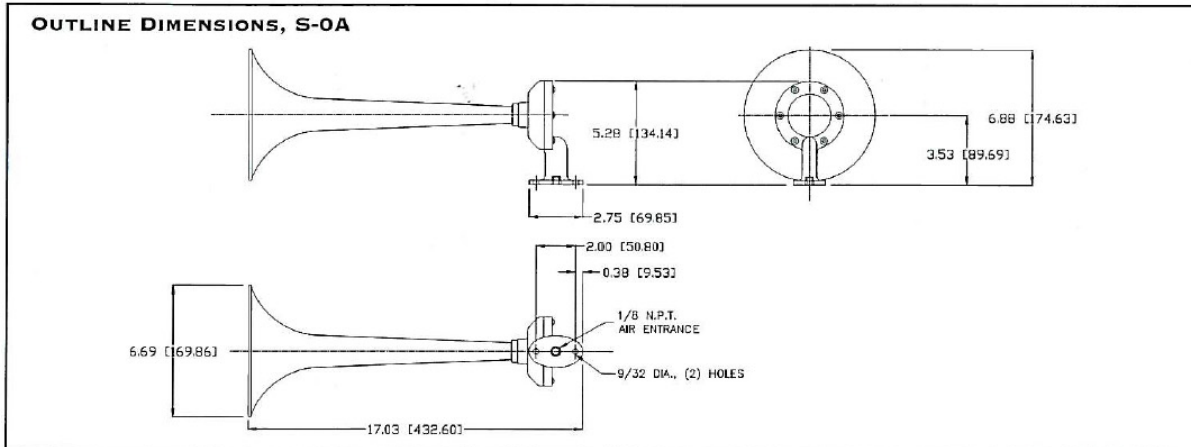

**MODEL D-0A
(CHROME FINISH)**

TECHNICAL DATA, D-0A

FREQUENCY: 322 & 254 HZ
 SOUND PRESS. LEVEL: 122.5 DB
 (1/3 OCTAVE @ 1M)
 AIR CONSUMPTION: 14 C.F.M.
 @ 100 P.S.I.
 AIR PRESSURE REQUIRED: 50 TO 200 P.S.I.
 MATERIAL: SPUN BRASS AND
 CAST BRONZE
 NET WEIGHT: 9 LBS.
 SHIPPING WEIGHT: 14 LBS.

Technical modifications reserved without prior notice

BETTER BY DESIGN **Kahlenberg**

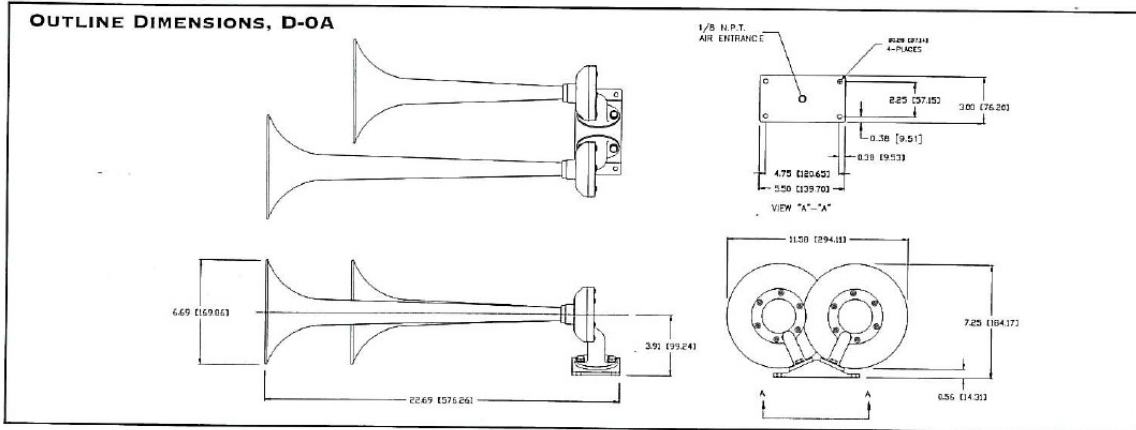

TECHNICAL DATA, T-OA

FREQUENCY: 322, 295, & 254 Hz
 SOUND PRESS. LEVEL: 123.3 dB
 (1/3 OCTAVE @ 1M)
 AIR CONSUMPTION: 21.5 C.F.M.
 @ 100 P.S.I.
 AIR PRESSURE REQUIRED: 50 TO 200 P.S.I.
 MATERIAL: SPUN BRASS AND
 CAST BRONZE
 NET WEIGHT: 16 LBS.
 SHIPPING WEIGHT: 22 LBS.

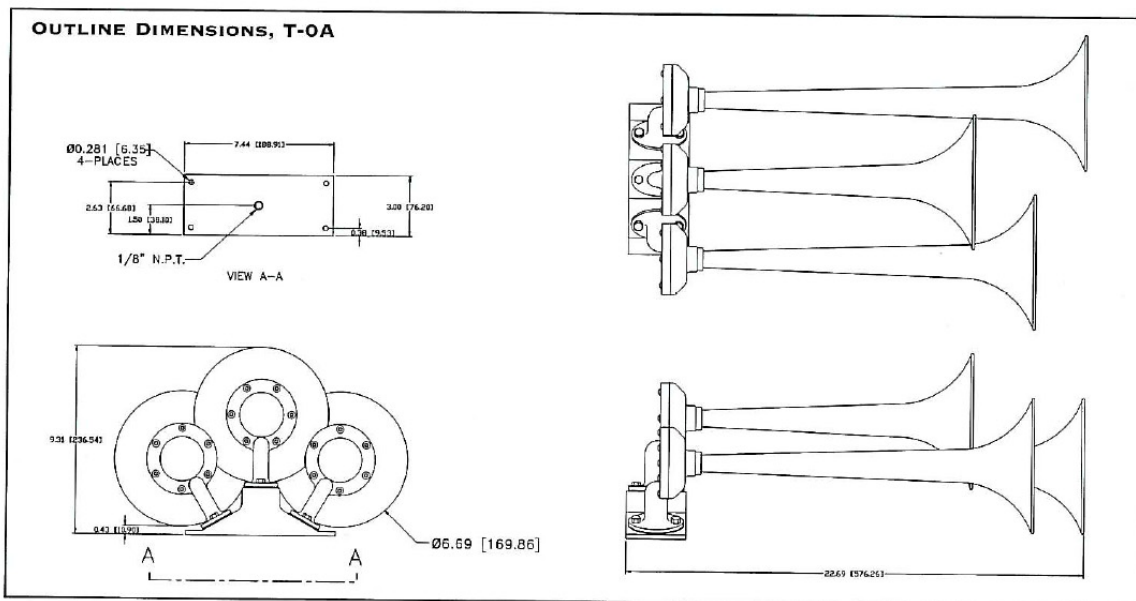

Technical modifications reserved without prior notice

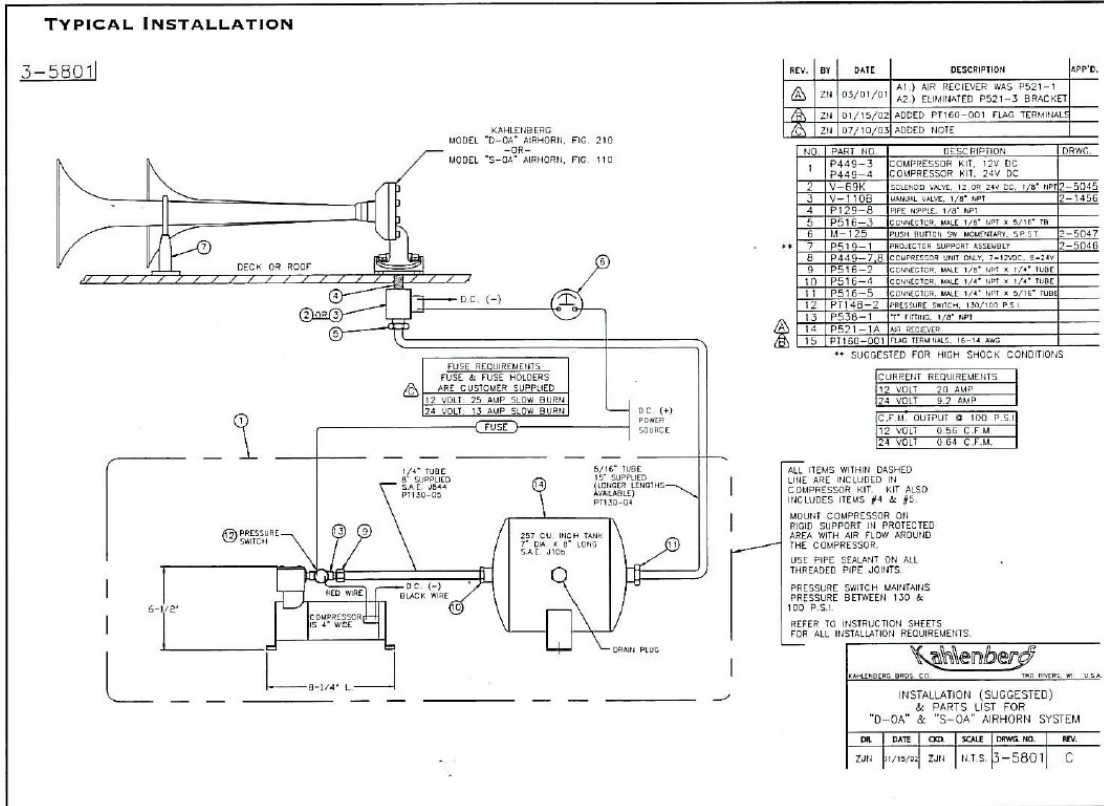

**** PLEASE NOTE THAT THE INSTALLATION OF THE T-OA REQUIRES A 7" X 18" AIR RECEIVER. ALL OTHER COMPONENTS ARE IDENTICAL. T-OA 12 VOLT D.C. COMPRESSOR KITS ARE ORDERED UNDER PART #P449-09, 24V. D.C. KIT IS PART #P449-10.

**** A COMPLETE AIRHORN SYSTEM SHOULD CONSIST OF THE S-OA, D-OA, OR T-OA WITH THE V-69K SOLENOID VALVE KIT, AND ONE OF THE P449 COMPRESSOR KITS.



A FAMILY OWNED CORPORATION SINCE 1895,
KAHLENBERG BROTHERS COMPANY CURRENTLY MANUFACTURES OVER TWO DOZEN DIFFERENT MODELS OF SOUND SIGNALS ACCEPTED BY THE U.S. COAST GUARD, AND CERTIFIED BY ABS AND THE BRITISH MCA, FOR VESSELS 20 METERS TO OVER 200 METERS IN LENGTH. FOR VESSELS OVER 20 METERS LONG OVERALL, PLEASE ASK FOR KAHLENBERG BULLETIN 104 AND 105.

Hear Kahlenberg Horns on the Internet at www.kahlenberg.com

KAHLENBERG BROTHERS COMPANY
1700 12TH STREET, P.O. BOX 358
TWO RIVERS, WISCONSIN 54241, U.S.A.
PHONE: 920-793-4507 FAX: 920-793-1346
www.kahlenberg.com

BULLETIN 102

Technical modifications reserved without prior notice